

Category 3, EN 954-1 PST 3

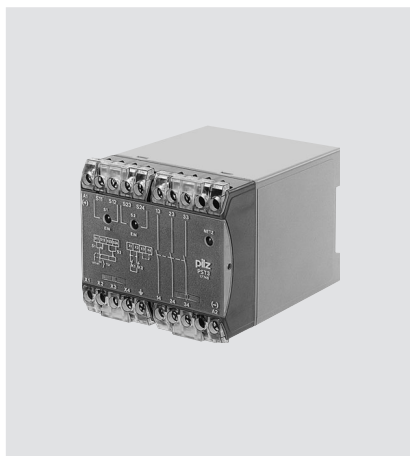

Emergency stop relay and safety gate monitor in accordance with VDE 0113-1, 11/98, EN 60204-1, 12/97 and IEC 204-1, 11/98.

Features

- Simultaneity monitoring can be selected
- Manual or automatic reset

Approvals

	PST 3
	●
TÜV Wien	●
	●
	●

Technical Details PST 3

Electrical Data

Supply Voltage	AC: 24, 42, 48, 110, 115, 120, 230, 240 V DC: 24 VDC
Tolerance	85 ... 110 %
Residual Ripple DC	Max. 120 %
Power Consumption	Approx. 3.5 W/6.5 VA
Voltage and Current at the Input and Reset Circuits and Feedback Control Loop	24 VDC, 50 mA

Switching Capability in accordance with

EN 60947-4-1, 02/01

AC1: 240 V/8 A/2000 VA
400 V/5 A/2000 VA

DC1: 24 V/8 A/200 W

EN 60947-5-1, 11/97 (DC13: 6 cycles/min.)

AC15: 230 V/5 A; DC13: 24 V/7,5 A

Output Contacts

3 safety contacts (N/O)

Contact Fuse Protection (EN 60947-5-1, 11/97)

10 A quick or 6 A slow

Times

Delay-on Energisation Approx. 300 ms

Delay-on De-energisation Approx. 50 ms

Recovery Time Approx. 100 ms

Simultaneity channel 1/2 Approx. 200 ms or ∞

Max. Supply Interruption before De-energisation 10 ms

Mechanical Data

Torque Setting on Connection Terminals 1.2 Nm (screws)

Maximum Cross Section of 2 x 2.5 mm²

External conductors Single-core or multi-core with crimp connectors

Dimensions (H x W x D) 87 x 90 x 110 mm

Weight AC: 480 g, DC: 390 g

Description

- 90 mm, P-75-housing, DIN-Rail mounting
- Positive-guided relay outputs:
 - 3 safety contacts (N/O)
- Connection for
 - E-STOP button
 - safety gate limit switch
 - reset button
- LEDs for channel 1 and channel 2 and power
- Increase in the number of safety contacts available by connecting expander modules.

Operating Modes

- Single-channel operation
- Dual-channel operation
- Automatic reset
- Manual reset

Category 3, EN 954-1 PST 3

Internal Wiring Diagram

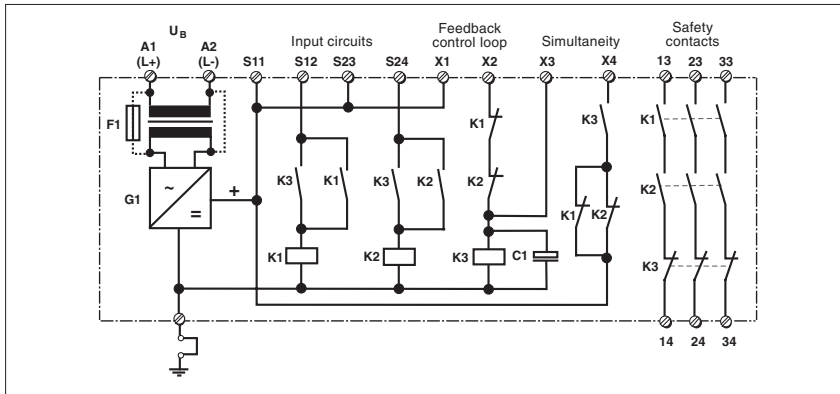

- Key

S1/S2: E-STOP or safety gate switch

S3: Reset button

Switch operated

Gate open

Gate closed

● Increase in safety contacts
The number of output contacts can be increased by using expander modules or relays/contactors with positive-guided contacts.

External Wiring

● Example 1
Single-channel E-STOP wiring with manual reset.

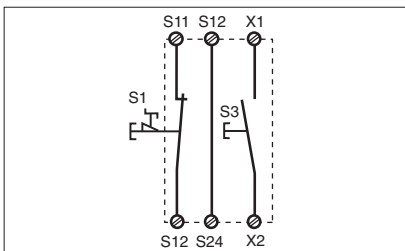

● Example 4
Dual-channel safety gate control with manual reset.

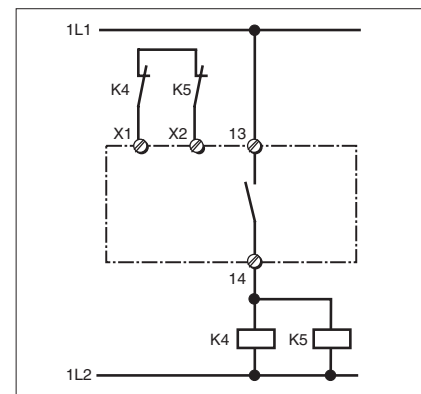
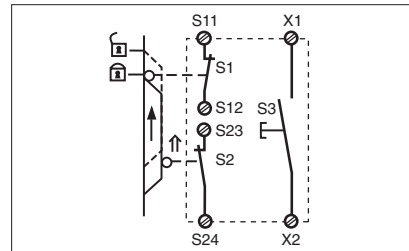

● Example 2
Dual-channel E-STOP wiring with manual reset.

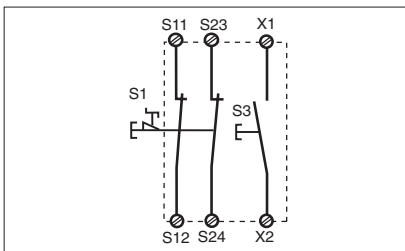

● Example 5
Dual-channel safety gate control with automatic reset.
Simultaneity: ∞

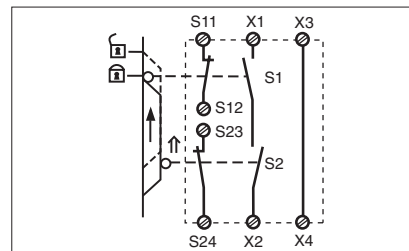

● Example 3
Single-channel safety gate control with manual reset.

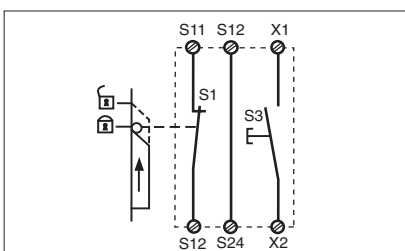

● Example 6
Dual-channel safety gate control with automatic reset.
Simultaneity: max. 200 ms.

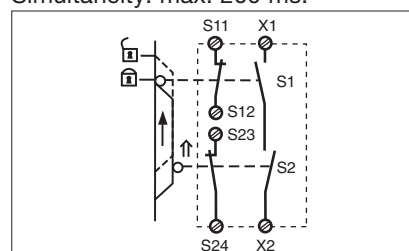

Category 3, EN 954-1 PST 3

General Technical Data

Unless stated otherwise in the technical details for the specific unit

Electrical Data

Frequency Range AC	50 ... 60 Hz
Residual Ripple DC	160 %
Contact Material	AgSnO ₂
Continuous Duty	100 %

Environmental Data

EMC	EN 50081-1, 01/92, EN 61000-6-2, 03/00
Vibration in accordance with EN 60068-2-6, 01/00	Frequency: 10 ... 55 Hz, Amplitude: 0.35 mm
Climatic Suitability	DIN IEC 60068-2-3, 12/86
Airgap Creepage	DIN VDE 0110 part 1, 04/97
Ambient Temperature	-10 ... +55 °C
Storage Temperature	-40 ... +85 °C

Mechanical Data

Torque Setting on Connection Terminals	0.6 Nm (screws)
Mounting Position	Any
Housing Material	Thermoplast Noryl SE 100
Protection	Mounting: IP 54 Housing: IP 40 Terminal Range: IP 20

The units were tested in accordance with the relevant standards current at the time of development.

Order References

Type	U _B	Order No.
PST 3	24 V DC	420 280
PST 3	24 V AC	420 200
PST 3	42 V AC	420 210
PST 3	48 V AC	420 220
PST 3	110 V AC	420 230
PST 3	115 V AC	420 235
PST 3	120 V AC	420 240
PST 3	230 V AC	420 250
PST 3	240 V AC	420 255