

Photoelectric identification codes

1.	2.	3.	4.	5.	6.	7.	8.	9.	10.	11.	12.	13.	14.	15.	16.	17.	18.	19.
O	M	1	2	R	T	-	D	H	T	P	-	0	2	0	0	-	C	L

- 1** O = Photoelectric sensor
- 2** M = Metric metal housing
T = Metric thermoplastic housing
R = Rectangular design
P = Pg..thread..size
Z = Cylindrical design
- 3/4** Specification of housing dimensions
e. g. 12 = M 12
18 = M 18
20 = 20 series
90 = 90 series
- 5/6** ES = Through-beam sensor (Complete set)
EE = Through beam, receiver only
SE = Through beam, transmitter only
LC = Fibre optic control (sensor with fibre optics connection)
RH = Diffuse reflective sensors with background suppression)
RS = Retroreflective sensor
RT = Diffuse reflective sensor
FF = Convergent beam sensor, fixed focus
PR = Print registration sensor
PS = Polarised retro sensor
- 7** Dash
- 8** Voltage type
A = AC
D = DC
M = Multivoltage
P = Programmable voltage (AC or DC)
- 9** Output function
A = Complementary LA/DA (light activated / dark activated)
D = Dark activated (DA)
H = Light activated (LA)
O = No output (through-beam transmitter)
P = Selectable LA/DA (light activated / dark activated)
X = Customer-specified output
- 10** Output type
A = Analogue output
N = NAMUR
O = No output
Q = Triac
R = Relay
S = Others
T = Transistor
Y = Thyristor
- 11** N = NPN transistor output (switched to negative)
P = PNP transistor output (switched to positive)
G = Push/pull
S = Through-beam light source
U = Switch selectable PNP/NPN
2 = 2-wire output
3 = 3-wire output
4 = 4-wire output
- 12** Dash
- 13-16** Sensing distance
Sensing distance specifications are always indicated by 4 digits
– mm: without decimal point
– m: with decimal point
e. g. 06.0 = 6 m
e. g. 15.0 = 15 m
e. g. 0500 = 500 mm
- 17** Dash
- 18** Connection type
A = Screw termination
B = Plug with screw terminals
C = Cable (standard C = 2 m or length in m)
S = Plug-in connector
- 19...** Options
C = Control/diagnostic input
D = LED for output indication
E = Adjustable sensitivity
F = Diagnostic circuit with output and LED for indicator
G = LED for output mode, supply voltage and beam control indication
H = LED for supply voltage and output mode indication
L = LED for output indicator
T = Adjustable timer circuit
V = LED for operating voltage indication
X = Customer-specific options
Z = Fixed timer

Wiring diagrams

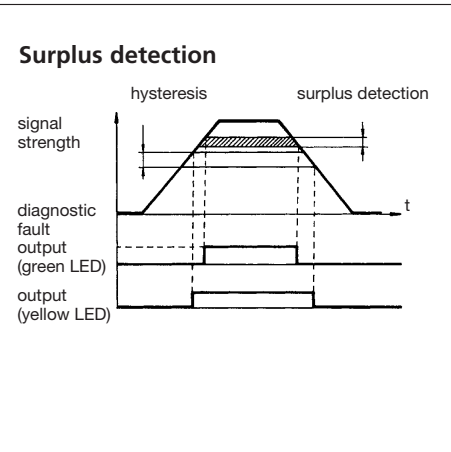
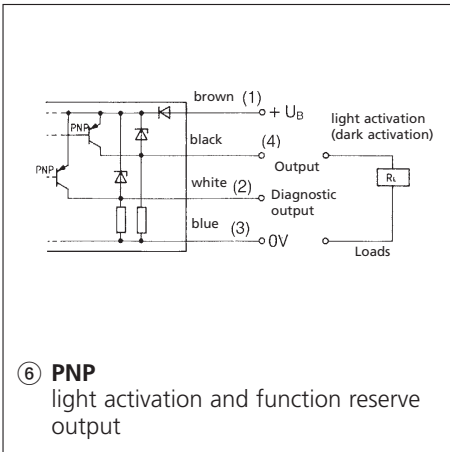
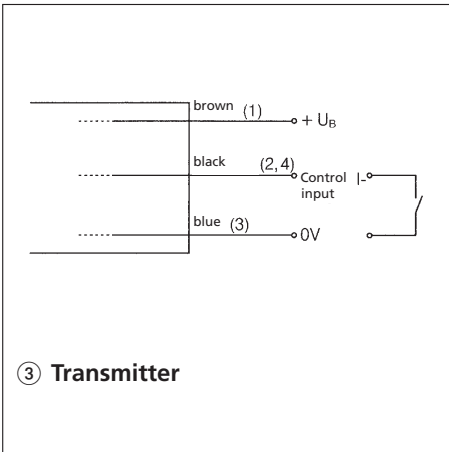
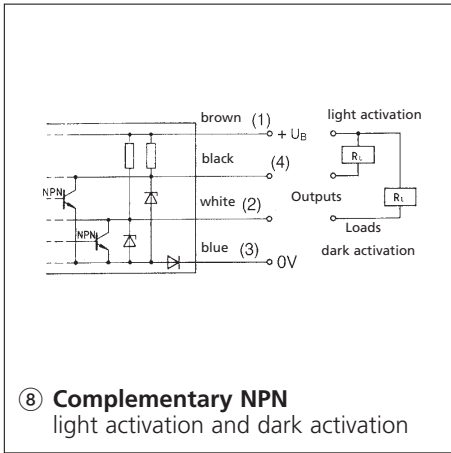
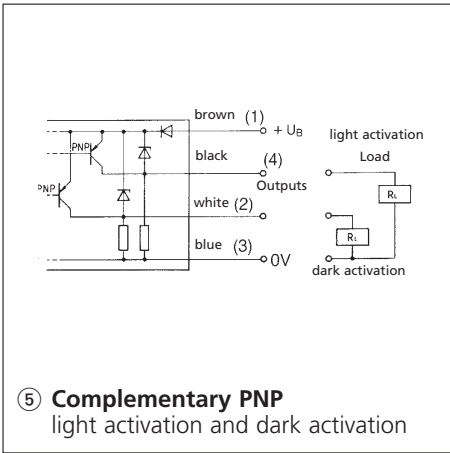
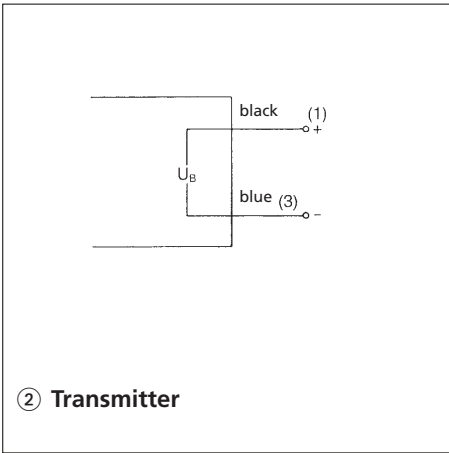
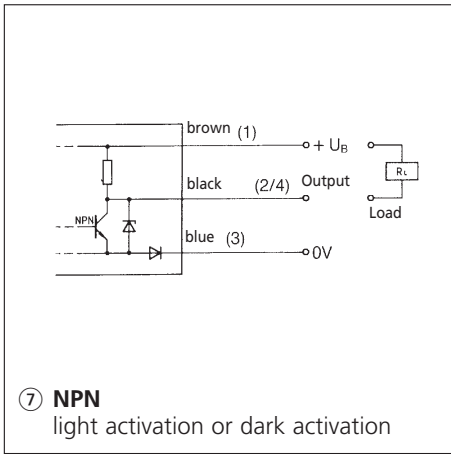
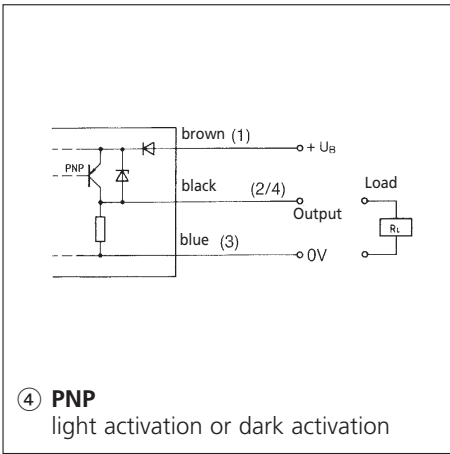
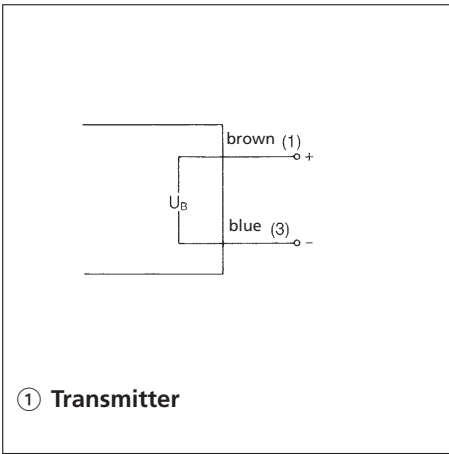

Wiring diagrams

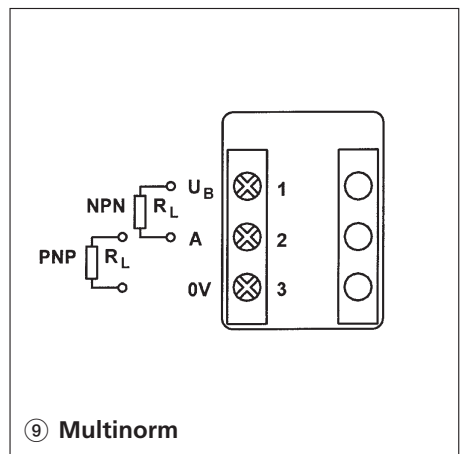
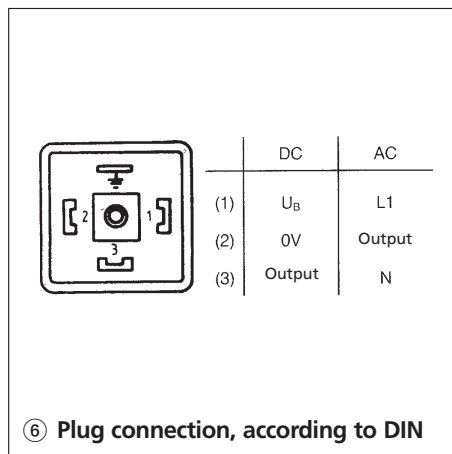
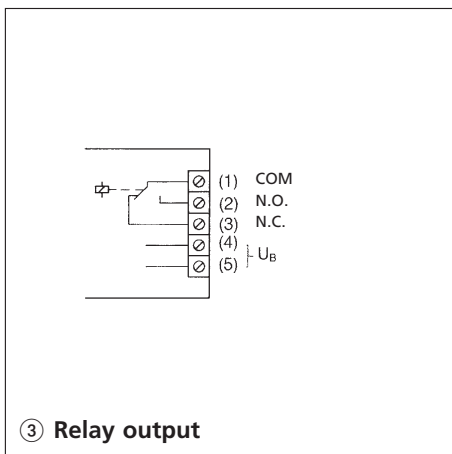
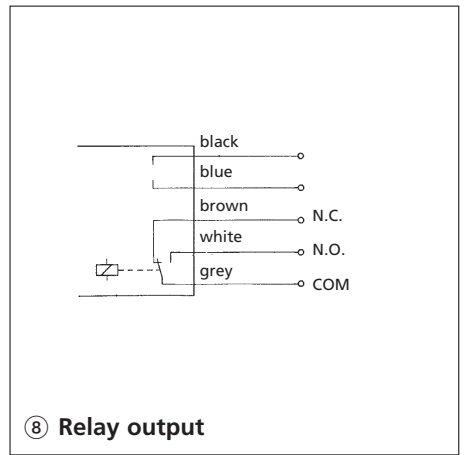
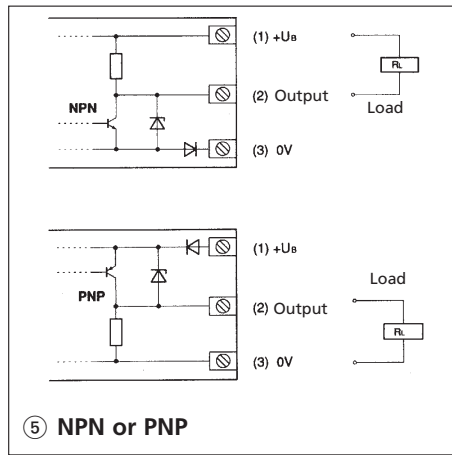
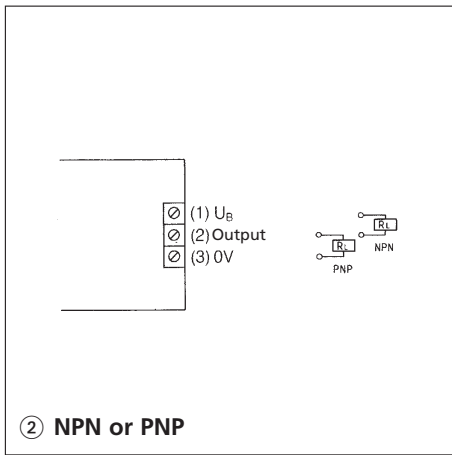
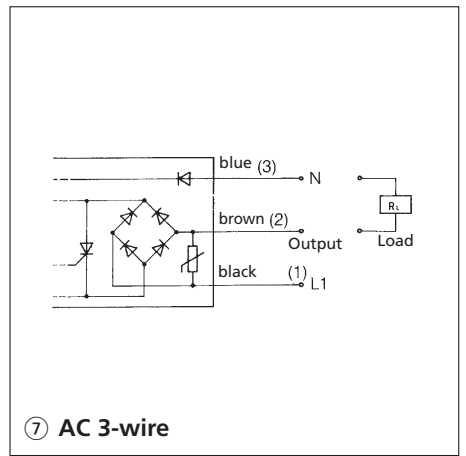
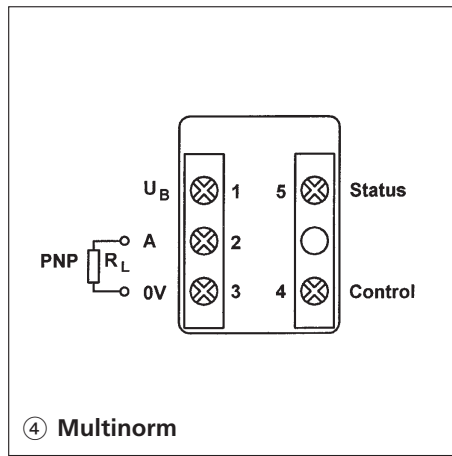
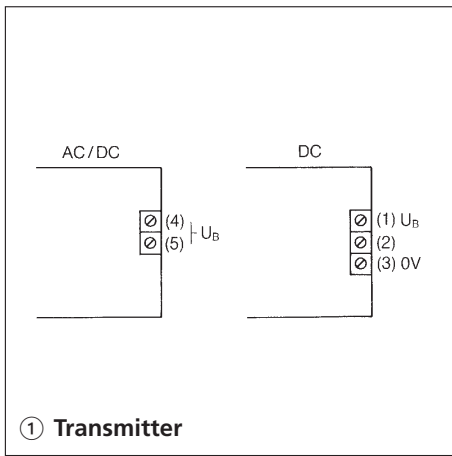

Fixing material

Other mounting brackets on request

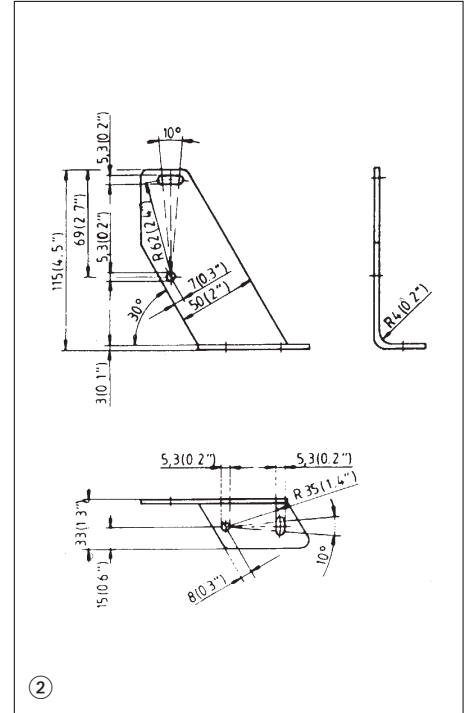
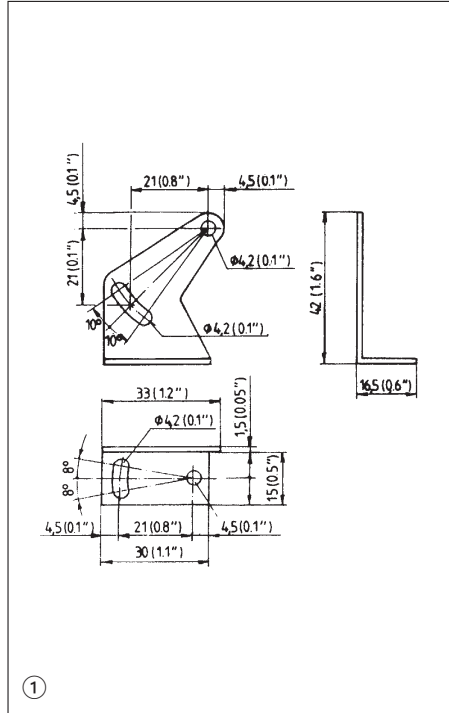

Model description	BWN-L05ST KPL	BWN-L20NI KPL
Part number	657.1300.003	657.1200.002
Stock status: Ex stock/Built to order	-/●	●/-

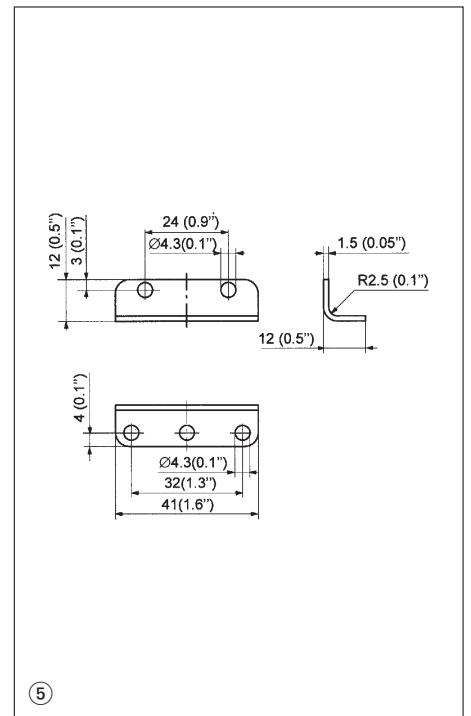
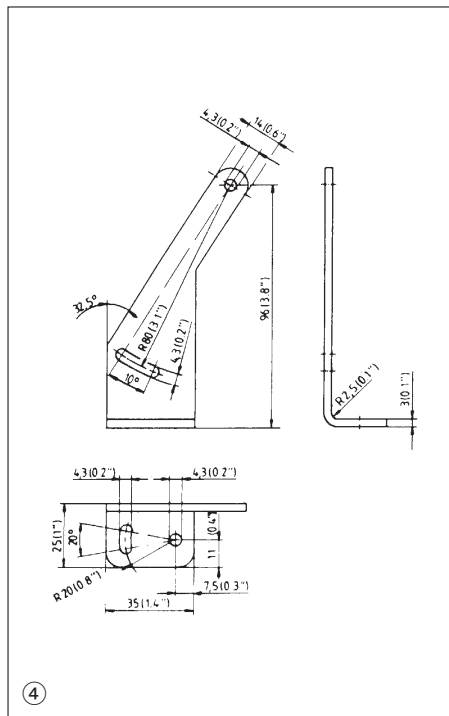
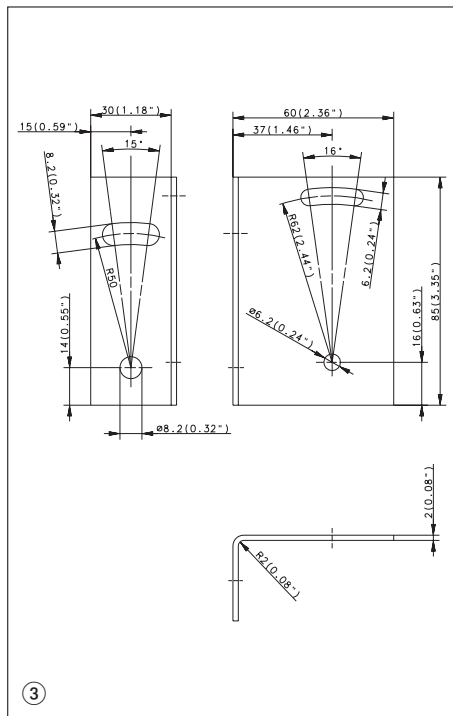

Model description	BWN-L20NI KPL	BWN-L90NI KPL	BWN-L12AL KPL
Part number	657.1200.007	657.1100.001	657.1500.006
Stock status: Ex stock/Built to order	●/-	●/-	●/-

Reflectors

A device called triple reflector is the best solution for the reflection in light barriers. Reflective foils play only a secondary role. Triple reflectors are pyramid-shaped small triple mirrors that are combined to make a single reflecting surface. These three reflecting surface are arranged in pyramid shape and in an angle of 90° to each other. They reflect the arriving light beam three times on a single mirroring surface and permit to return it into its original direction (180° reversion). Vibrations, minor movements and variations of up to 30° in relation to the optical axis of the triple reflector do not break the light beam.

Reflective foils may also be horizontally swung or tilted. However, compared to triple reflectors, their degree of reflection is much decreased as their operation principle is based on small mirrors in connection with micro glass beads. An advantage of reflective foil is its high agree of mounting flexibility. Its reflective performance may be increased by using foil with triple structure, however it does not come near the reflection degree of triple reflectors. In principle a plane mirror should not be used, except when the light beam's angle of incidence corresponds with a high precision to the angle of reflection. Only then a reflection of the light beam can be assured.

The sensing distance specifications of retro-reflective sensors refer to reflectors from the RTS-083 KK or RTS-060 KK series. Basically, the reflector diameter should be selected with regard to the sensing distance and the size of the object to be detected. The ideal case is when the object is larger than the reflector, which is then "shadowed" completely.

Example: OR20RS

Reflector	Sensing distance
RTS-D17 KK	3.2 m
RTS-D22 KK	3.5 m
RTS-D32 KK	4.0 m
RTS-D83 KK	8.0 m
RTS-60 KK	8.0 m
RFS-100 KK	6.0 m
RTS-120 KK	3.5 m
RTS-500 KK	7.0 m

Contact our technical marketing service to obtain information on the sensing distances of other convergent-beam light barriers.

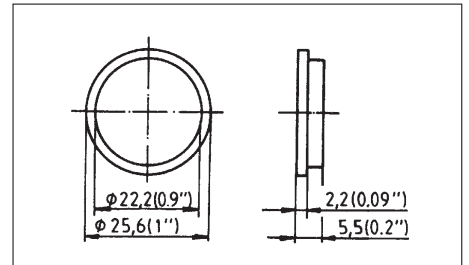
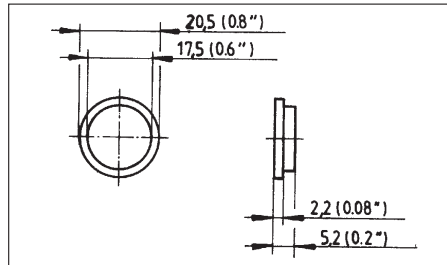

Model description	RTS-D17 KK	RTS-D22 KK
Part number	657.2108.008	657.2109.009
Diameter	17.5 mm (0.69")	22 mm (0.86")
Stock status: Ex stock/Built to order	●/–	●/–

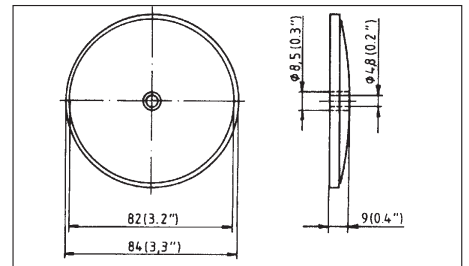
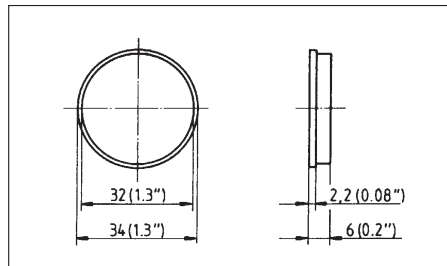

Model description	RTS-D32 KK	RTS-D83 KK
Part number	657.2110.010	657.2107.003
Diameter	32 mm (1 1/4")	83 mm (3 1/4")
Stock status: Ex stock/Built to order	●/–	●/–

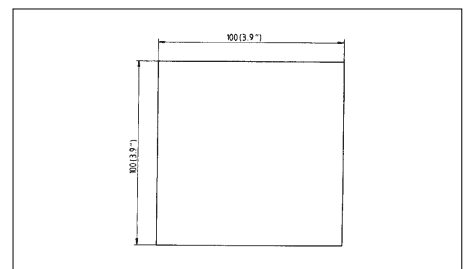
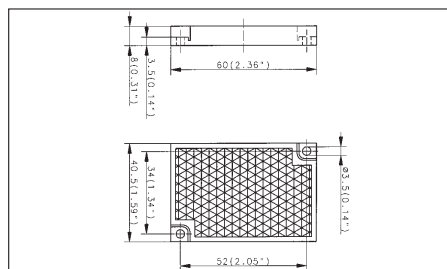

Model description	RTS-60 KK	RFS-100 KK
Part number	657.2100.007	657.2300.001
Dimensions	60x41 mm (2.36"x1.61")	100x100 mm (3.9"x3.9") foil with self adhesive backing
Stock status: Ex stock/Built to order	●/–	●/–

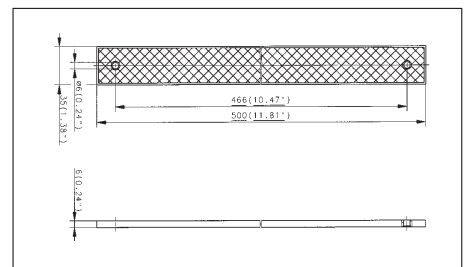
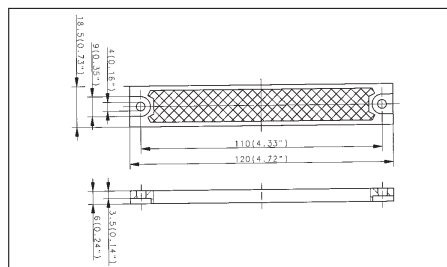

Model description	RTS-120 KK	RTS-500 KK
Part number	657.2100.006	657.2100.002
Dimensions	120x18 mm (4.72"x0.71")	500x35 mm (19.7"x1.38") plastic
Stock status: Ex stock/Built to order	●/–	●/–

Fibre optics for OR05 series

-40 °C/+ 75 °C
-40 °F/+167 °F

with plastic sleeve

All plastic fibre deliveries include a cutting tool.

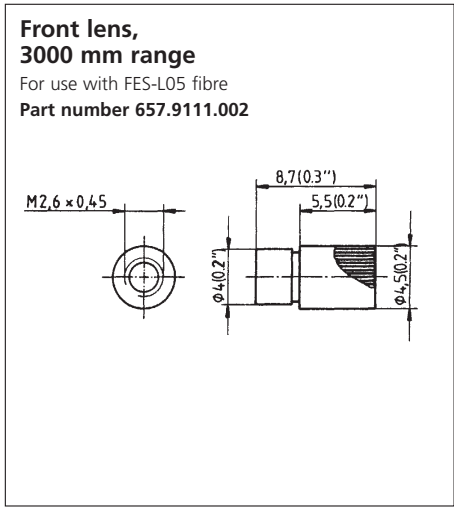
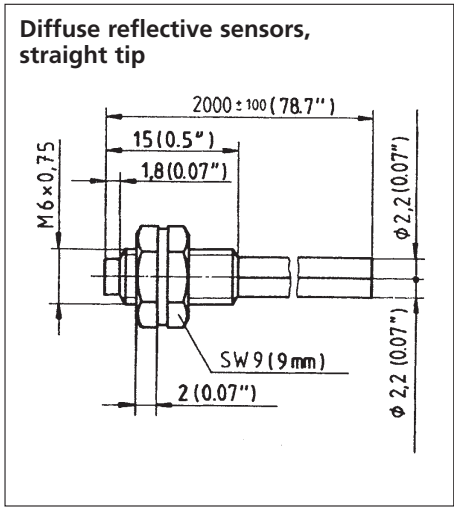
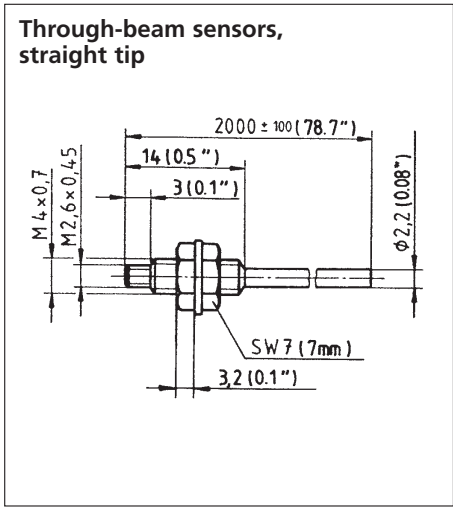

Sensing distance/range	200 mm (7.87")	120 mm (4.72")	
2 single fibres, type can be cut	Ø 2.2 mm (0.09")	Ø 2.2 mm (0.09")	
Model description	FES-L05KK/2.0-V	FRS-L05KK/2.0-V	VLS-L05GM/000-M2.6
Part number	657.9111.002	657.9711.001	657.0022.011 (1 unit)
Stock status: Ex stock/Built to order	●/-	●/-	-/●

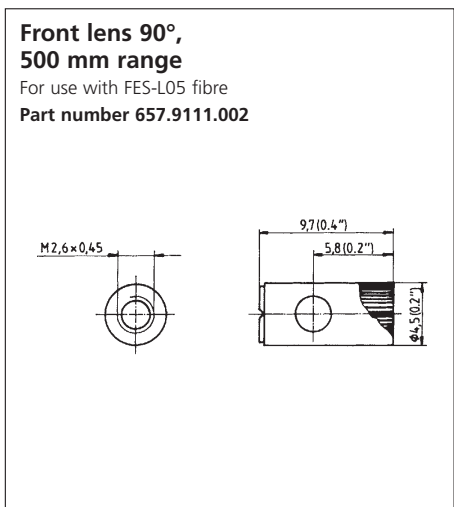
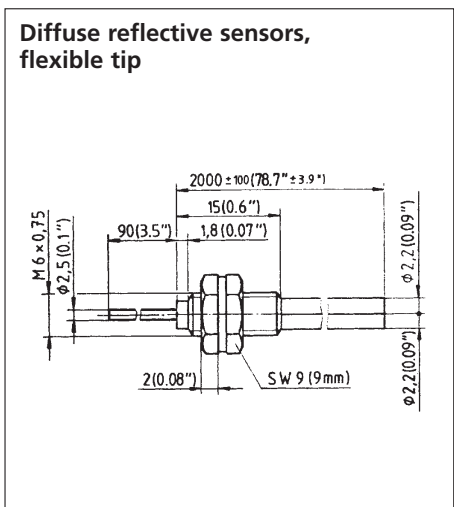
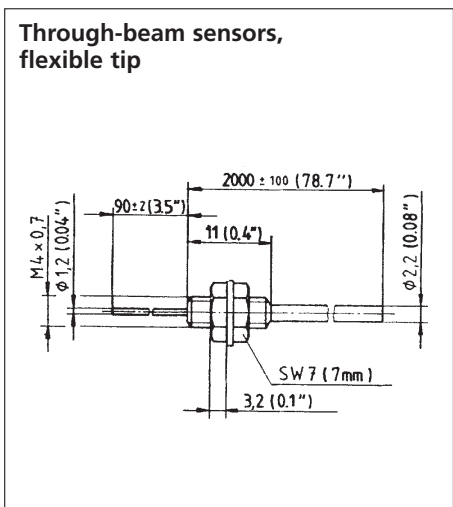

Sensing distance/range	120 mm (4.72")	120 mm (4.72")	
2 single fibres, type can be cut	Ø 2.2 mm (0.09")	Ø 2.2 mm (0.09")	
Model description	FES-L05KK/2.0-BV	FRS-L05KK/2.0-BV	VLS-L05GM/000-M2.6W
Part number	657.9111.001	657.9711.002	657.0022.008 (1 unit)
Stock status: Ex stock/Built to order	-/●	●/-	-/●